

## Products Features

- ▶ High uniformity.
- ▶ Adding intensifying film, intensity can be increased by 20%~50%.
- ▶ Usually, be used for profile inspection.

## Applications the light be used for

- Profile and dimension measuring.
- Scratch, dirty, internal foreign, damage inspection of transparent objects.
- Damage and foreign substance inspection of glass.

## Model Description

SBS-BAL-XXXXX-X

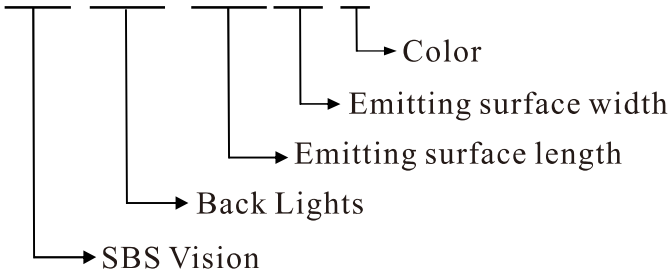

## Customization

- Dimensions
- Connector
- Power
- Cable length
- Mounting
- Color

## Structure

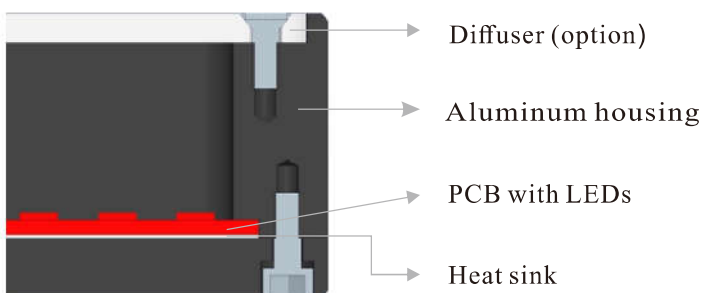

## Components

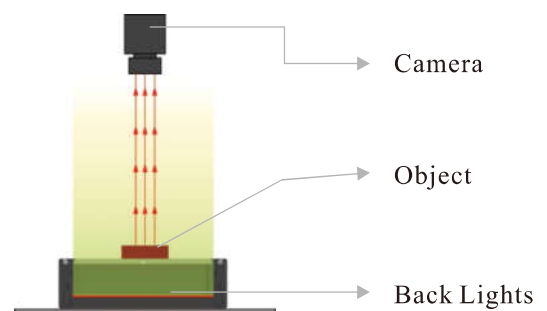

## Parameter

Item	Model	Power consumpition Red Color	Power consumpition (W,B,G)	Option	Extension cable	Recommended Controller
1	SBS-BAL2828-X	24V/1.0W	24V/1.58W	Diffuser	1m/3m/5m	SBS-AC24XX-X (Analog controller) SBS-DC24XX-X (Digital controller) SBS-ODC48XX-X (Strobe controller)
2	SBS-BAL3325-X	24V/0.86W	24V/1.44W	Diffuser	1m/3m/5m	
3	SBS-BAL5450-X	24V/1.72W	24V/2.59W	Diffuser	1m/3m/5m	
4	SBS-BAL7070-X	24V/3.45W	24V/4.89W	Diffuser	1m/3m/5m	
5	SBS-BAL8080-X	24V/3.60W	24V/6.62W	Diffuser	1m/3m/5m	
6	SBS-BAL9090-X	24V/5.47W	24V/8.06W	Diffuser	1m/3m/5m	
7	SBS-BAL100100-X	24V/6.91W	24V/10.08W	Diffuser	1m/3m/5m	
8	SBS-BAL120120-X	24V/9.79W	24V/14.40W	Diffuser	1m/3m/5m	
9	SBS-BAL150150-X	24V/12.48W	24V/18.72W	Diffuser	1m/3m/5m	
10	SBS-BAL200200-X	24V/18.96W	24V/28.32W	Diffuser	1m/3m/5m	
11	SBS-BAL250250-X	24V/25.68W	24V/38.40W	Diffuser	1m/3m/5m	

## Dimensions(mm)

<p style="text-align: center;">SBS-BAL2828-X</p>	<p style="text-align: center;">SBS-BAL3325-X</p>
<p style="text-align: center;">SBS-BAL5450-X</p>	<p style="text-align: center;">SBS-BAL7070-X</p>

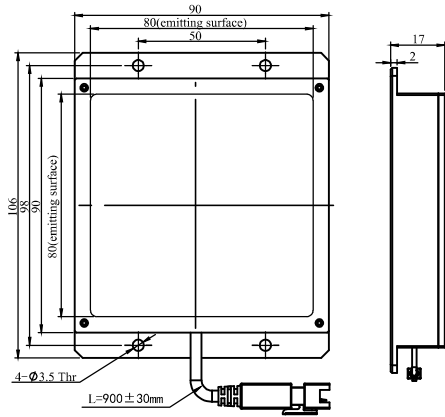

SBS-BAL8080-X

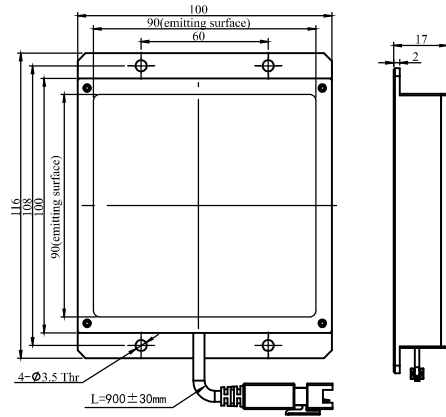

SBS-BAL9090-X

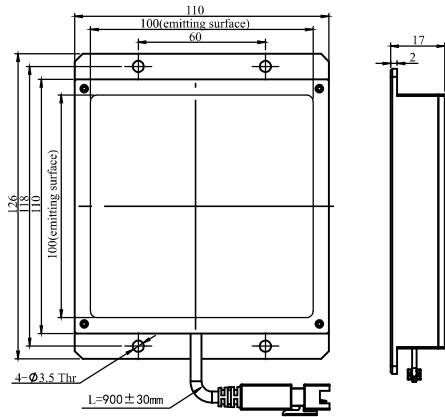

SBS-BAL100100-X

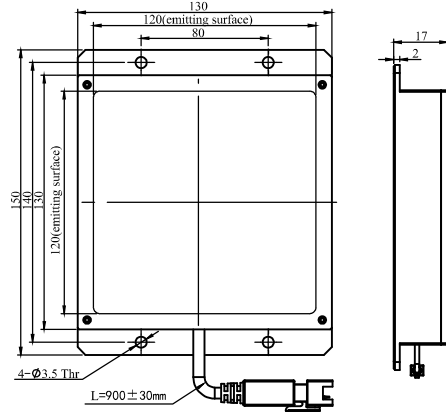

SBS-BAL120120-X

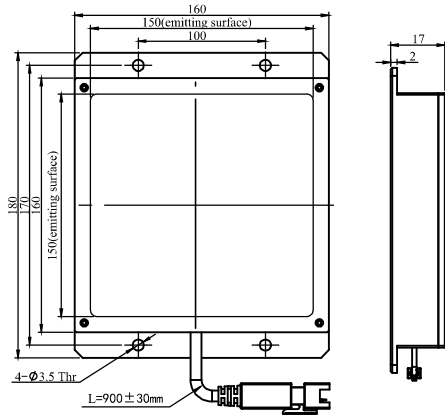

SBS-BAL150150-X

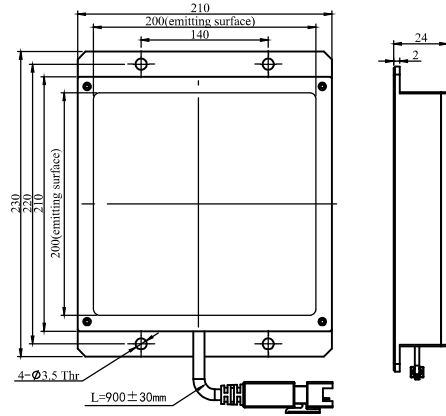

SBS-BAL200200-X

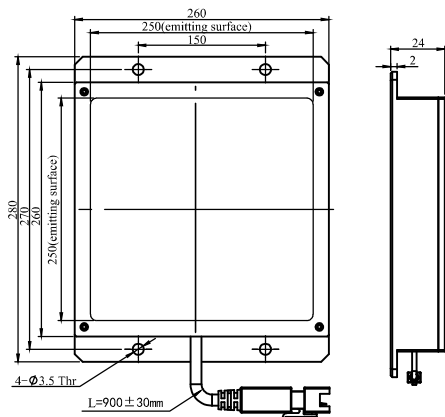

SBS-BAL250250-X